

DE-BUG magnetic diesel filter is the Patented and proven cure of diesel bug, including microbial contamination. DE-BUG is a one time fit and forget solution and once installed in the fuel line, the DE-BUG treatment unit cleans and polishes your diesel fuel as your appliance is operating.

DeBug L1000

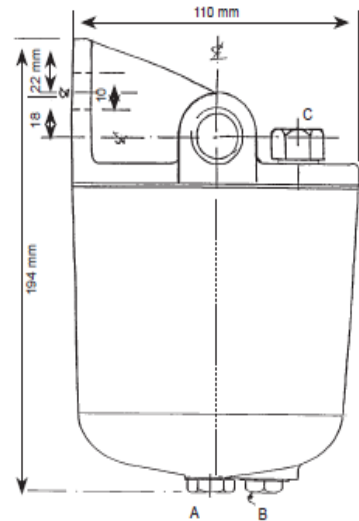

FUEL TYPES	Diesel fuel, marine diesel, light oils and gas oil
RECOMMENDED FLOW RATE	Up to 1000 litres/hour
FLOW DIRECTION WITH UNIT MOUNTED	Left to Right and Right to Left on request
MATERIALS	Marine grade LM6 anti-corrosive aluminium alloy.
WEIGHT	1.98 Kg
SIZE	110mm diameter by 194 mm high by 114 mm wide.
PORT SIZE	7/8" UNF
OPERATING PRESSURE	50 psi
INSTALLATION	Two 10mm bolts.

